

DESCRIPTION

The PVC5800 series is a fully calibrated, temperature-compensated vacuum transducer designed for cost-effective OEM integration. It combines a MEM Pirani sensor with a MEMS piezoresistive pressure sensor to extend the measurement range from 1 mTorr to ATM with excellent accuracy.

The Pirani sensor is based on Posifa's proven, third-generation MEMS thermal conduction chip that operates under the principle that the thermal conductivity of gases is proportional to their vacuum pressure.

The electronics and microprocessor amplify and digitize the sensor signal, and provide a digital output via an I²C interface. Because the thermal conductivity of a vacuum varies with the ambient temperature, a temperature compensation algorithm is implemented in the microprocessor, taking input from a built-in temperature sensor.

Connected to the same I²C bus is a MEMS piezoresistive pressure sensor that provides accurate vacuum measurement from 10,000 mTorr to ATM.

To facilitate integration, the PVC5800 includes a connector-terminated wire harness, and supports ISO-KF and NPT fittings.



FEATURES

- Range: 1 mTorr to 760,000 mTorr (0.013 Pa to 101 kPa)
- Accuracy: 15 % reading from 15 mTorr to 10,000 mTorr, and 15 % from 10,000 mTorr to ATM
- Fast response time: 250 ms
- Digital I²C interface
- Low power consumption for battery-powered instruments
- Temperature compensation
- Resistant to contamination

APPLICATIONS

- Leak detection in any closed system maintained under primary vacuum pumps, such as in vacuum-insulated panels
- Digital vacuum gauges

ABSOLUTE MAXIMUM RATINGS

- Operating temperature: -25 °C to 85 °C
- Storage temperature: -40 °C to 90 °C
- Shock: 100 g peak (5 drops, 3 axis)
- Overpressure: 27.5 bar

ELECTRICAL CHARACTERISTICS

Test Conditions: Vdd = 3.3 Vdc, Ta=21°C

SPECIFICATIONS	MIN	TYP	MAX	UNIT	CONDITIONS
Measurement Principle	Thermal conductance according to Pirani, and piezoresistive pressure sensor				
Range	1 x 10 ⁻¹		760,000	mTorr	Air, O ₂ , CO, N ₂
	0.013		101,000	Pa	
	1.3 x 10 ⁻⁴		1,013	mbar	
Output Count	1		65535	Count	I ² C address 0x50 (TC sensor)
Output Reading	1,333		101,000	Pa	I ² C address 0x6D (piezoresistive pressure sensor)
Accuracy		50 %		Reading	1 mTorr to 14 mTorr
		15 %		Reading	15 mTorr to 10,000 mTorr
		15 %		Reading	10,000 mTorr to 760,000 mTorr (266 mbar to 1013 mbar)
Resolution		1 %		Reading	
Repeatability		2 %		Reading	
Response Time		250		ms	
Supply Voltage		3.3		Vdc	
Operating Current		22		mA	
Operating Temperature	-20		85	°C	
Temperature Compensation	5		60	°C	
Storage Temperature	-40		90	°C	
Wetted Materials ¹	SS 316F, Epoxy, FR4, glass, Ni, Si, Au				

Note:

1. A parylene coated version is available where internal wetted materials such as FR4 and Ni are coated with parylene C.

OUTPUT DESCRIPTION

I²C implementation should read both TC Pirani sensor (0x50) and piezoresistive pressure sensor (0x6D) at the same time. From the I²C reading, two values will be obtained.

1. I²C 0x50 = counts in mTorr
2. I²C 0x6D = value in Pa

IF I²C 0x50 count ≤ 10,000

Micron/mTorr reading = count (from I²C 0x50)

IF I²C 0x50 count > 10,000 then use the value from I²C 0x6D as the main reading

Pa reading = value in Pascal (from I²C 0x6D)

GAS TYPE DEPENDENCE

Calibration is based on air, and valid for O₂, N₂, and CO. For other gas types, a calibration factor must be applied to the pressure reading. Please contact Posifa Technologies for the calibration factor of a specific gas type.

LOW-POWER OPERATION

For battery-powered instruments that require a further reduction in power consumption, we recommend powering the PVC5800 in an intermittent mode:

1. Turn on the PVC5800
2. Wait for 300 ms
3. Read from the I²C interface (both 0x50 and 0x6D address)
4. Turn off the PVC5800
5. Wait for 1 second and repeat from Step 1

PACKAGE DIMENSIONS

PVC5816

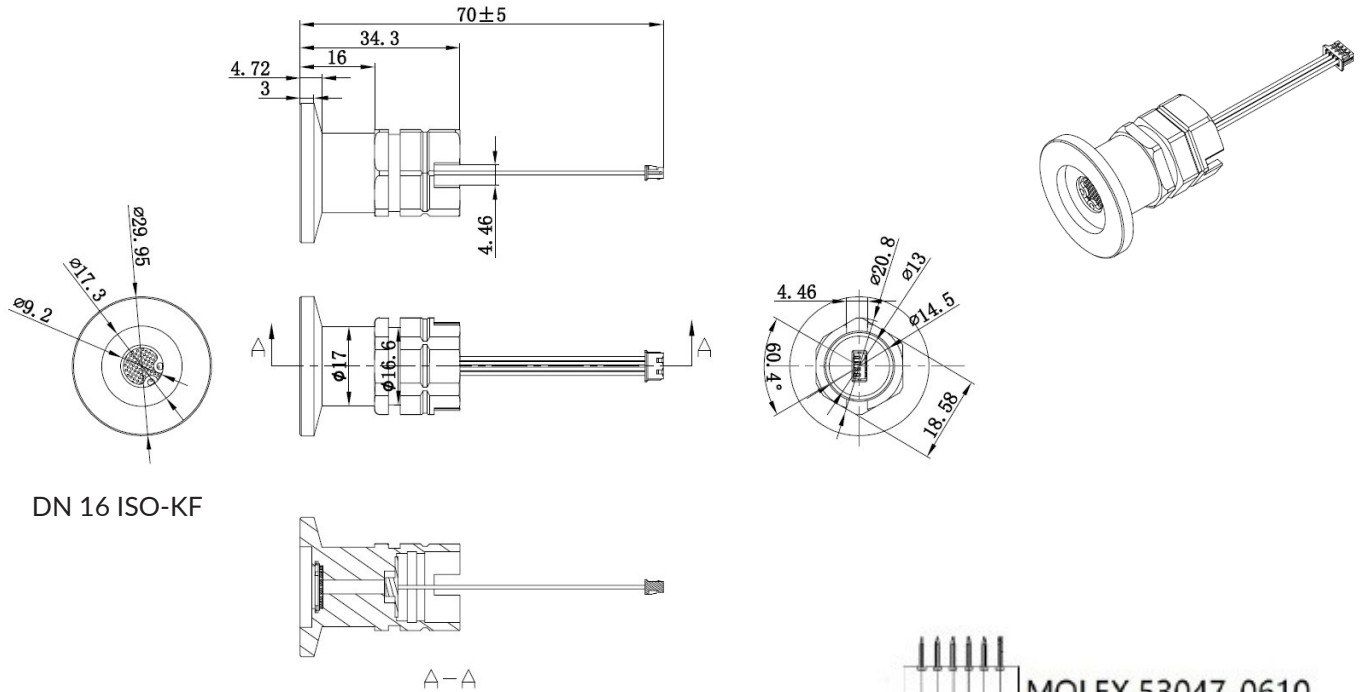

DN 16 ISO-KF

A-A



Pad/Wire#	Description (Wire Color)
1	Vdd (Red)
2	GND (Black)
3	SDA (Yellow)
4	SCL (Green)
5	ICPCK (for firmware update) (Blue)
6	ICPDA (for firmware update) (White)

Note: The PVC5800 comes with a wire harness that is soldered onto the PCB. The length is 56 mm (2.2 inch). The wire harness is terminated with a Molex connector P/N 51021-0600.

ORDERING INFORMATION

PART NUMBER	SPECIFICATIONS
PVC5816	10 ⁻³ Torr to 760 Torr, I ² C Output, DN 16 ISO-KF Fitting

Please contact Posifa or your [local distributor](#) to place an order.