

## DESCRIPTION

The PVC4100 is a fully calibrated, temperature-compensated vacuum transducer designed for cost-effective OEM integration. It consists of a MEMS thermal conduction sensor (Pirani sensor), measuring electronics, and a microprocessor, packaged in an ultra-compact PCB assembly.

The sensor element is based on Posifa's proven, second-generation MEMS thermal conduction chip that operates under the principle that the thermal conductivity of gases is proportional to their vacuum pressure.

The electronics and microprocessor amplify and digitize the sensor signal, and provide the output via an I<sup>2</sup>C interface. Because the thermal conductivity of a vacuum varies with the ambient temperature, a temperature compensation algorithm is implemented in the microprocessor, taking input from a built-in temperature sensor.

To facilitate integration, the PVC4100 includes a connector-terminated wire harness that is soldered onto the PCB assembly.



## FEATURES

- Range: 0.1 mTorr to 760,000 mTorr (0.013 Pa to 101k Pa)
- Fast response time: 250 ms
- Low power consumption for battery-powered instruments
- Temperature compensation
- Resistant to contamination

## APPLICATIONS

- Leak detection in any closed system maintained under primary vacuum pumps, such as in vacuum-insulated panels
- Digital vacuum gauges

## ABSOLUTE MAXIMUM RATINGS

- Operating temperature: -25 °C to 85 °C
- Storage temperature: -40 °C to 90 °C
- Shock: 100 g peak (5 drops, 3 axis)
- Overpressure: 27.5 bar

## ELECTRICAL CHARACTERISTICS

Test Conditions: Vdd = 3.3 Vdc, Ta=21°C

SPECIFICATIONS	MIN	TYP	MAX	UNIT	CONDITIONS
Measurement Principle	Thermal conductance according to Pirani				
Range <sup>1</sup>	1 x 10 <sup>-1</sup>		760,000	mTorr	Air, O <sub>2</sub> , CO, N <sub>2</sub>
	0.013		101,000	Pa	
	1.3 x 10 <sup>-4</sup>		1,013	mbar	
Output Count	1		65535	Count	
Accuracy <sup>1</sup>		15 %		Reading	1 mTorr to 200,000 mTorr (10 <sup>-3</sup> mbar to 266 mbar)
		50 %		Reading	10 <sup>-1</sup> micron to 1 micron (10 <sup>-4</sup> mbar to 10 <sup>-3</sup> mbar)
		50 %		Reading	200,000 mTorr to 760,000 mTorr (266 mbar to 1013 mbar)
Resolution		1		mTorr	
Repeatability		2 %		Reading	
Response Time		250		ms	
Supply Voltage		3.3		Vdc	
Operating Current		22		mA	
Operating Temperature	-20		65	°C	
Temperature Compensation	5		60	°C	
Storage Temperature	-20		65	°C	
Wetted Materials	Epoxy, FR4, glass, Ni, Si, Au				

Note:

1. To achieve the range and accuracy below 1 mTorr and above 10 Torr as specified herein, the master MCU must implement the extended calibration table as defined in our application note "[Achieving High Accuracy in the Low Vacuum Range With Posifa's PVC4000/PVC5000.](#)"

---

## OUTPUT DESCRIPTION

---

### **IF count $\leq$ 10,000**

Micron/mTorr reading = count

### **IF count $>$ 10,000**

Micron/mTorr reading =  $13.5 * (\text{count} - 10,000) + 10,000$

To achieve the range and accuracy as defined in specifications (i.e. below 1 mTorr and above 10,000 mTorr), the master MCU must implement the extended calibration table as defined in our application note "[Achieving High Accuracy in the Low Vacuum Range With Posifa's PVC4000/PVC5000.](#)"

---

## LOW-POWER OPERATION

---

For battery-powered instruments that require a further reduction in power consumption, we recommend powering the PVC4100 in an intermittent mode:

1. Turn on the PVC4100
2. Wait for 300 milliseconds
3. Read from the I<sup>2</sup>C interface
4. Turn off the PVC4100
5. Wait for 1 second and repeat from Step 1

## PACKAGE DIMENSIONS

### PVC4100

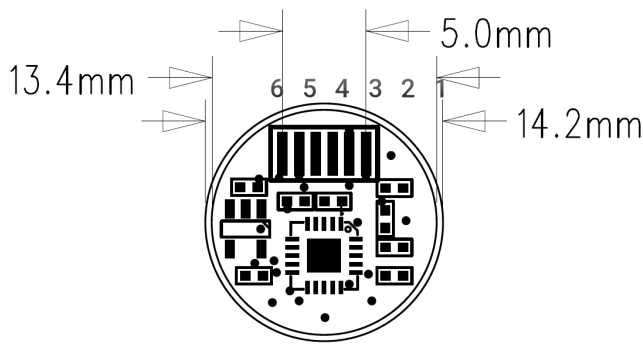

Top

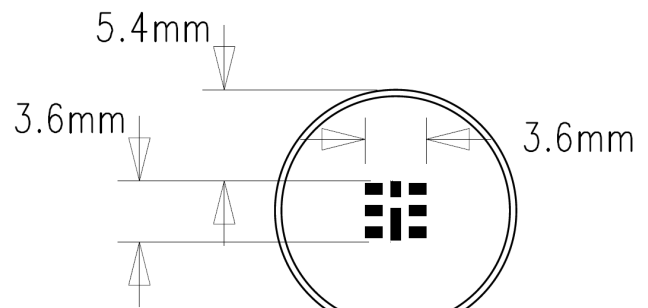

Bottom

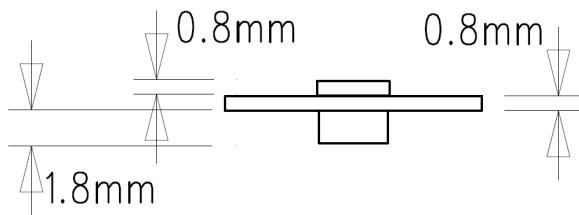

Side

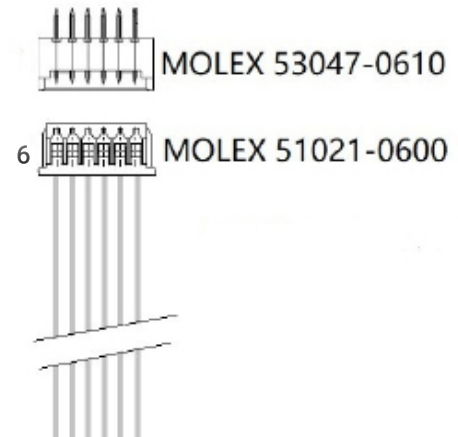

Pad/Wire#	Description (Wire Color)
1	Vdd (Red)
2	GND (Black)
3	SDA (Yellow)
4	SCL (Green)
5	ICPCK (for firmware update) (Blue)
6	ICPDA (for firmware update) (White)

Note: The PVC4000 comes with a wire harness that is soldered onto the PCB. The length is 56 mm (2.2 inch). The wire harness is terminated with a Molex connector P/N 51021-0600.

## ORDERING INFORMATION

PART NUMBER	SPECIFICATIONS
PVC4101	10 <sup>-3</sup> Torr to 760 Torr, SMD sensor, calibrated and temperature-compensated

Please contact Posifa or your [local distributor](#) to place an order.